

11	1	ROTATIONAL CORE	CF1001-Q1
10	2	HOOK	CF1002-I11
9	1	WALL BALL TARGET (ø355)	CF1002-O1
8	1	DIP HORN (900x600)	CF1001-M
7	1	PLYO BOX BOARD	CF1001-L5
6	5	MONKEY BAR (1080)	CF1002-C2
5	2	CHIN-UP BAR (1080)	CF1002-F2
4	2	MONKEY BAR (1800)	CF1002-C1
3	2	CROSS BAR (1800)	CF1002-E1
2	1	J HOOKS (1080)	CF1001-D1
1	4	UPRIGHT TUBE (2742)	CF1002-A1
N.	Qtà	Descrizione	Codice

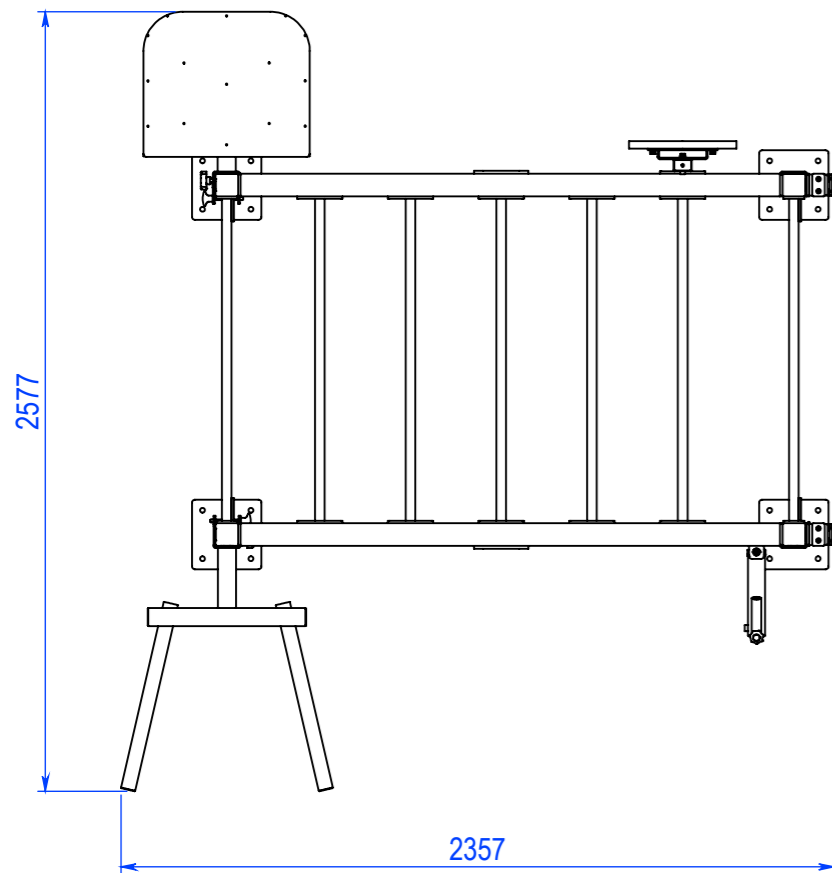
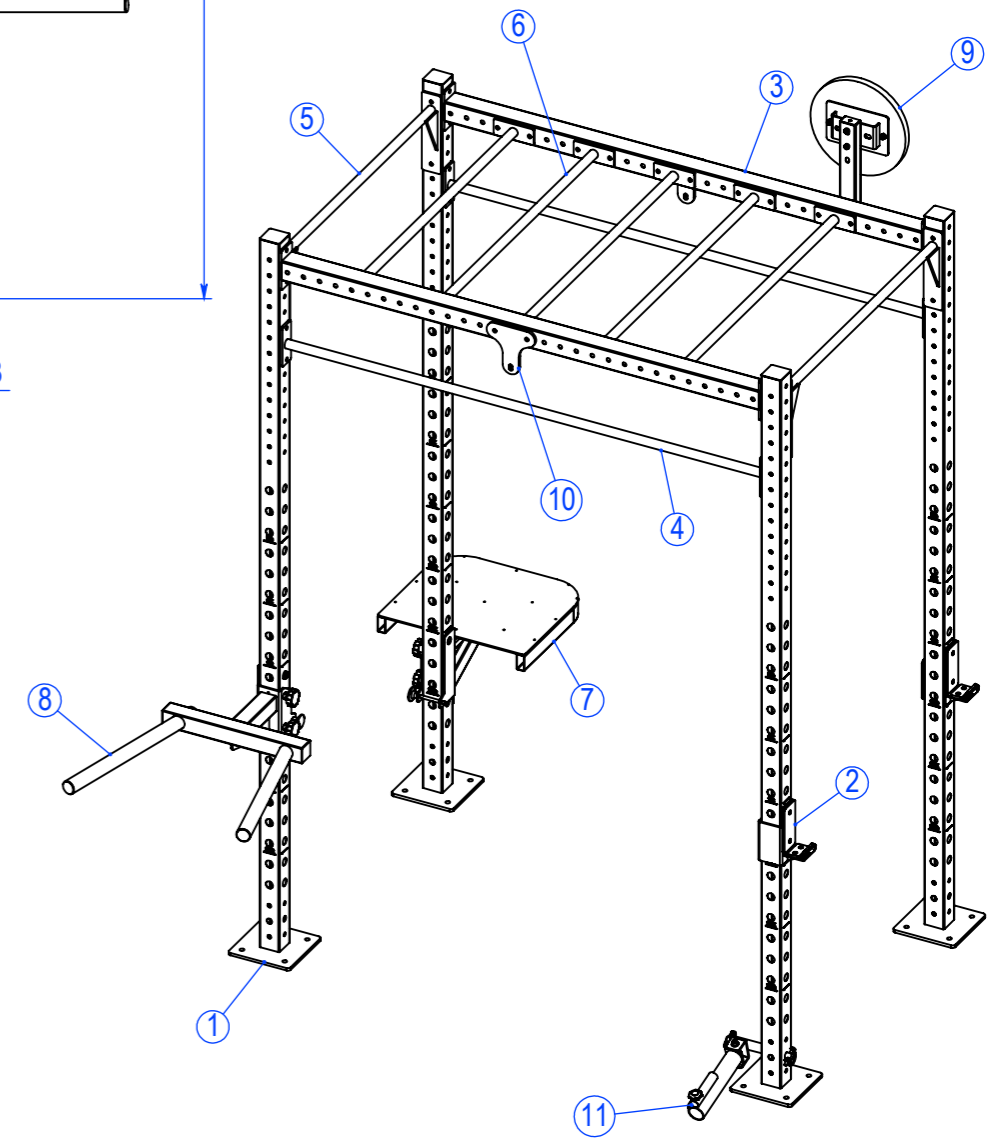

Last Edit	First release		
Material ///	TOLERANCES WHERE NOT SPECIFIED ACCORDING TO UNI EN 22768/1-2	WE RESERVE THE PROPERTY OF THIS DOCUMENT. ANY TOTAL OR PARTIAL REPRODUCTION WILL BE PURSUED TO THE LAW.	
Description CROSSRIG AUTOPORTANTE STAR TRAC			
	Des. <i>[Signature]</i>	App.	Scale 1:25
	Date 10/03/26		Code StarTracGr 1,80x1,08